



9460-ET SERIES



Today in Process Automation many different methods are used to power and to communicate with end devices. Such methods may include 4-20mA; a variety of different fieldbus standards; serial communications - including RS232, RS422 and RS485; video; telephony and Ethernet.

Where applications require high bandwidth, Ethernet is the ideal solution as it provides open connectivity and can be combined with Ethernet Remote I/O and Linking Devices to connect to low bandwidth 4-20mA and fieldbus systems. But Ethernet has rarely been used in hazardous areas because of the high cost involved and the limitations involved in order to carry out maintenance.

The 9460-ET Series provides cost-effective Intrinsically Safe (IS) Ethernet equipment that can be installed and maintained easily in hazardous areas. The intrinsically safe hazardous area certification permits the components to be mounted in a Zone 1 hazardous area with connectivity into Zone 0 and the associated apparatus certification of the 9468-ET IS Ethernet isolator and 9491-PS IS power supply allow this equipment to be mounted in a Zone 2 hazardous area and connected to intrinsically safe equipment in a Zone 0 or 1 hazardous area.

In Process Automation it is also preferable to use a single cable to provide both power and communications to the end device. The 9460-ET Series can deliver Intrinsically Safe Power over Ethernet (PoEx™) with a single Cat 5e or Cat 6 cable, allowing *live connection and disconnection* of the end device in Zone 0 and 1 hazardous areas.

The 9461-ET Ethernet Gateway provides existing intrinsically safe equipment with "Ethernet connectivity" by allowing conventional serial communication equipment to be connected to an Ethernet network. Many intrinsically safe devices such as analysers, weighing systems, dust monitors, etc. have RS232, RS422 or RS485 serial connectivity. Providing these devices with Ethernet connectivity offers considerable hardware and integration cost savings.

The 9465-ET Copper to Fibre Optic Media Converter enables an Ethernet network to be extended over a much greater distance. A fibre optic link running at 100Mbps can go distances of up to 2 km, or an extended distance of 5 km is achievable at 10Mbps.

The 9466-ET Ethernet switch allows the interconnection of intrinsically safe Ethernet networking components via its 5 ports. It also enables a copper Ethernet network to be extended beyond the 100 metre distance limit between Ethernet devices.

The 9468-ET is an intrinsically safe Ethernet isolator enabling Ethernet devices in Zone 2, or a safe area, to communicate with intrinsically safe Ethernet networking components operating in the hazardous area. A further application is the use of a pair of 9468-ET isolators to permit an Ethernet cable to cross a hazardous area.

The 9469-ET Intrinsically safe Wireless LAN product is a multi-functional module that can be used as an 802.11a/b/g/h Access Point, a Wireless Bridge or a Wireless Repeater. Many end users have recognised the benefits of giving mobile operators access to control and maintenance system data.



A choice of intrinsically safe PDAs and Zone 2 PCs offering 802.11 wireless connectivity is now available. The 9469-ET offers lower costs and easier maintenance for WLAN equipment installed in hazardous areas, compared to the alternative of large, expensive flameproof enclosures fitted with specialist certified antennas.

The 9491-PS Power Supply is the preferred method for supplying the 9460-ET Series of IS Ethernet Modules as it is based on an isolating power supply. It takes a 24V DC Safe Area/Zone 2 supply and produces an Intrinsically Safe 12V DC nominal output capable of powering the Ethernet modules mounted in a Zone 1/Division 1 hazardous area.

The 9466-ET Ethernet Switch and the 9468-ET IS Ethernet Isolator are capable of distributing power to compatible devices connected to their IS ports providing Power over Intrinsically Safe Ethernet (PoEx™) via the RJ45 Cat5e cables. This method eliminates the need for a separate power supply cable to each Ethernet device; simplifying both installation and maintenance. A 9491-PS power supply is required to power the 9466-ET and an additional 9491-PS is required for each powered Ethernet port. Similarly, one 9491-PS is required to power the IS Ethernet port of the 9468-ET IS Ethernet Isolator. The 9461-ET, 9465-ET and 9469-ET can be powered directly from a 9491-PS intrinsically safe power supply or using Power over IS Ethernet (PoEx™).

The MTL IS Ethernet applications range from immediate needs for Hazardous Area WLAN infrastructure; IS serial device connectivity; and Ethernet connections across hazardous areas to long term opportunities to develop Ethernet field devices.

APPLICATIONS

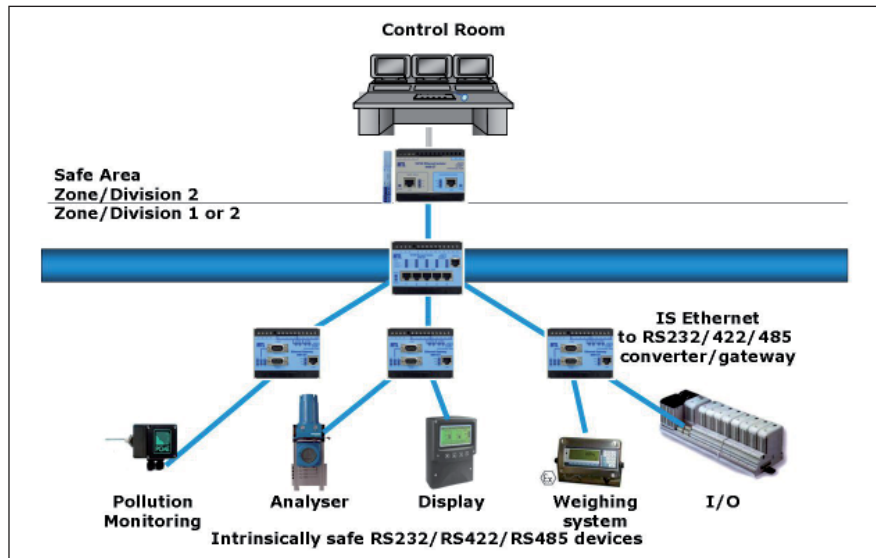

9461-ET Ethernet Gateway connects to intrinsically safe RS232, RS422 and RS485 devices

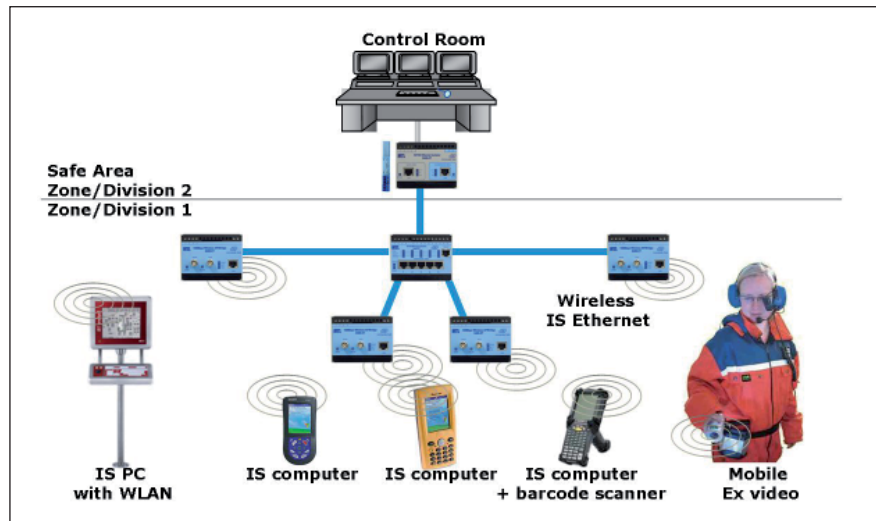

9469-ET Wireless LAN Access Point connects to a wide choice of IS PDAs and Zone 2 PCs

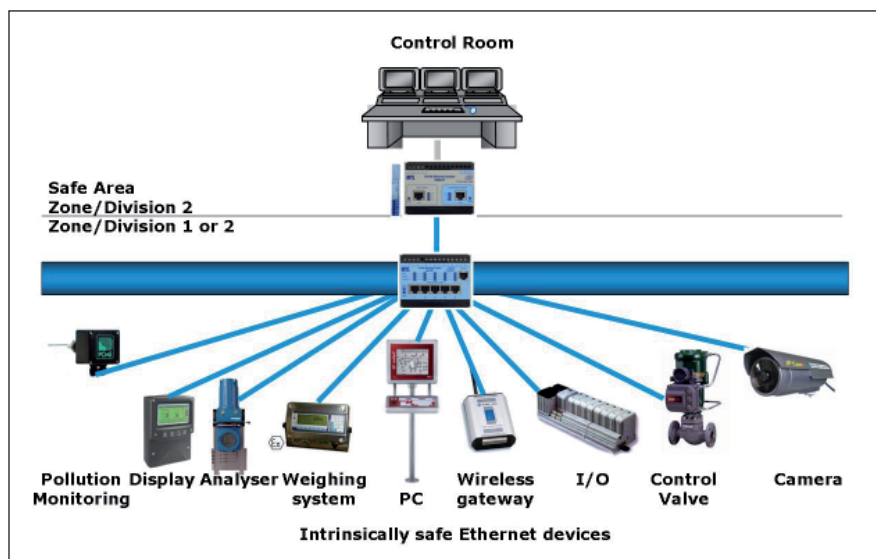

9466-ET Ethernet Switch connects directly to Intrinsically Safe Ethernet devices





9461-ET



- ◆ **Serial to Ethernet Gateway**
- ◆ **Zone 1 mountable in IP6x enclosure**
- ◆ **Four serial-port intrinsically safe inputs:
2 x RS232/TTL
2 x RS485/RS422**
- ◆ **10/100Mbps Ethernet**
- ◆ **ATEX / IECEx certified**
- ◆ **FM / CSA approvals (pending)**
- ◆ **Wide temp. range -20°C to +70°C**
- ◆ **High Performance 32-bit processor**
- ◆ **PoEx™ Power over IS Ethernet option**

The 9461-ET Ethernet Gateway gives existing intrinsically safe equipment "Ethernet connectivity" by allowing conventional serial communication port equipment to be connected to an Ethernet network.

Two 9-way D-type serial ports are provided which are RS232/TTL compatible. In addition, the module's front panel screw terminals (T6 - T15) provide two RS485/RS422, 2- or 4- wire ports, giving a total of four serial ports. All ports can operate at speeds up to 115K2baud.

Various protocols are available (eg: Serial Modbus, Modbus/TCP, Ethernet IP etc) in addition to Serial Tunnelling.

The 9461-ET is designed for Zone 1 hazardous-area mounting inside a suitable IP6x enclosure and has intrinsically safe ATEX and IECEx approvals with FM and CSA approvals pending. The approvals cover both surface industry and mining applications.

The design is based on a high performance ARM9 155MHz 32-bit RISC Processor (ARM926EJ-S).

The gateway may be powered by an intrinsically safe power supply or by Power over IS Ethernet (PoEx) providing intrinsically safe power and Ethernet communications over a single Cat5e cable.

10/100Mb Ethernet twisted pair (Cat5e) RJ45 connection (100metres length max).

Status LEDs are provided on the front panel to indicate:

- 'Power On'
- Network Link established
- Tx/Rx activity for all COM ports

Configuration is via a Microsoft® Windows™ interface which enables the IP address and the protocol conversion to be defined.

The Gateway can also act as the host processor for the 9466-ET Managed Ethernet Switch giving remote access to the switch's management features over the Ethernet network.

The module is supplied as a DIN-rail mounting device.

Microsoft is a registered trademark of Microsoft Corporation
Windows is a trademark of Microsoft Corporation
PoEx is a trademark of Controlled Systems Limited.



SPECIFICATION

See also System Specification

POWER INPUT

PoEx or separately powered

Input voltage

12V DC (10–15.4V)

Input current

150mA

Input protection

Fuse + supply reversal diode

ETHERNET

Intrinsically Safe 10/100 base T

Connector

RJ45

PoEx

Powered Device

IS SERIAL CONNECTIONS

	RS232	RS422/485
No. of channels	2	2
Connector Type	DB-9 male	Screw terminals
Baudrate	300-115K2 baud	300-115K2 baud
Parity	Even/Odd/None	Even/Odd/None
Data Bits	8	8
Stop Bits	1	1
Flow Control	RTS/CTS/XON/XOFF	XON/XOFF

RS232 Pin 9 power output

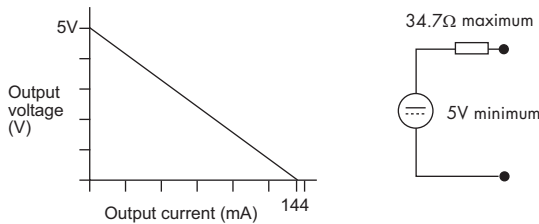

SAFETY

Location of module

Zone 1, IIC T4 hazardous area or Class 1, Div 1*, Groups A, B, C, D T4 hazardous location

Location of field wiring

Zone 0, IIC T4 hazardous area or Class 1, Div 1*, Groups A, B, C, D T4 hazardous location

* Certification pending

Ethernet protection

Intrinsically safe

Certification Code

See approvals

Safety description

See certificate

MECHANICAL

Mounting

DIN rail

Dimensions (mm)

Length 75

Width 100

Height (off rail) 116

Weight

1200 g

LED INDICATORS

	OFF	FLASH	ON
PWR (green)	Power fail	N/A	Power OK
WDG (red)	Watchdog Fault	Healthy (10Hz)	Watchdog Fault
TX (x4) (green)	Idle	Transmitting Serial Data	N/A
RX (x4) (red)	Idle	Receiving Serial Data	Fault – RX data polarity is inverted
STAT (red)	Status is Normal	Not used at present	Not used at present
ACT (yellow)	Ethernet link disconnected	Ethernet link activity	Ethernet link connected
100 (green)	Ethernet link set to 10Mbps	N/A	Ethernet link is 100Mbps

ENVIRONMENTAL

Ambient temp

Operating –20°C to +70°C

Storage –20°C to +70°C

Relative Humidity

5 to 95% RH (non-condensing)

Ingress Protection

IP20 to BS EN 60529

(Additional protection by means of enclosure)

DATA & POWER TERMINALS

COM 1 & 2 (DB-9 male)

RS232/TTL Ports

Pin	Function
1	DCD
2	RxD
3	TxD
4	RS232/TTL *
5	Signal Ground 0V
6	N/C
7	RTS
8	N/C
9	+5V o/p

LAN (RJ45)

10/100 BASE-T Ethernet

Pin	Function
1	Tx +
2	Tx –
3	Rx +
4	Supply 12V - PoEx †
5	Supply 12V - PoEx †
6	Rx –
7	Supply 0V - PoEx †
8	Supply 0V - PoEx †

* Pin 4 - O/C for RS232, connect to pin 5 for TTL levels

Screw Terminals †

PWR	Function
1	+12V DC in
2	+12V DC in
3	0V
4	0V

Terminals 1+2 and 3+4 are linked internally.

† When using PoEx, no supply is required on screw terminals 1 to 4

COM3	COM4	RS485	RS422
6	11	+ Tx/Rx	Tx +
7	12	- Tx/Rx	Tx –
8	13	-	Rx +
9	14	-	Rx –
10	15	Signal Ground 0V	



EUROPE (EMEA)
AMERICAS
ASIA PACIFIC
E-mail: enquiry@mtl-inst.com

Tel: +44 (0)1582 723633
Tel: +1 603 926 0090
Tel: +65 6 487 7887

Fax: +44 (0)1582 422283
Fax: +1 603 926 1899
Fax: +65 6 487 7997

Web site: www.mtl-inst.com



9465-ET



- ◆ **Copper to Fibre Optic Converter**
- ◆ **10/100Mbps wire speed**
- ◆ **Extend up to 5km (10Mbps)**
- ◆ **Zone 1 mountable in IP6x enclosure**
- ◆ **Transparent operation**
- ◆ **Choice of fibre optic connection styles**
- ◆ **ATEX / IECEx certified**
- ◆ **FM / CSA approvals (pending)**
- ◆ **Wide temp. range -20°C to +70°C**
- ◆ **PoEx™ Power over IS Ethernet option**

The 9465-ET 10/100Mbps Copper to Fibre Optic Media Converter allows an Ethernet network to be extended over a greater distance. The fibre optic link may be up to 2km in length when running at 100Mbps and due to the use of 1300nm optics an extended distance of 5km is achievable at 10Mbps.

Longer distances are obtained by simply connecting a 9466 (10/100Mbps Ethernet Switch) between two 9465 media converters, effectively giving a 'repeater' function (This also provides 3x UTP ports available for local network connectivity), this can be repeated as required.

The use of fibre optics gives exceptional immunity to noise and electrical interference, it is also used when connecting a Hazardous Area network to a Zone 2 / Safe Area network or device.

The 9465-ET is designed for Zone 1 hazardous-area mounting inside a suitable IP6x enclosure and has intrinsically safe ATEX and IECEx approvals with FM and CSA approvals pending. The approvals cover both surface industry and mining applications.

Fibre Optic connection options:

- ST style 62.5/125µm Multimode (9465-ET-M-ST)
- SC style 62.5/125µm Multimode (9465-ET-M-SC)
- SC style 9µm Single-mode (9465-ET-S-SC)

The converter may be powered by an intrinsically safe power supply or by Power over IS Ethernet (PoEx) providing intrinsically safe power and Ethernet communications over a single Cat5e cable.

Status LEDs are provided on the front panel to indicate:

- 'Power On'
- Fibre Optic 'Link 10Mb or 100Mb' established
- Fibre Optic 'Tx/Rx Activity'
- Copper UTP 'Link 10Mb or 100Mb' established
- Copper UTP 'Tx/Rx Activity'

10/100Mb Ethernet twisted pair (Cat5e) RJ45 connection (100metres length max).

Transparent operation - 10/100Mbps, Full/Half Duplex with Auto-Negotiation. Supports IEEE 802.3: 10Base-T, 10Base-FL, 100Base-TX and 100Base-FX/SX.

The module is supplied as a DIN-rail mounting device.

PoEx is a trademark of Controlled Systems Limited



SPECIFICATION

See also System Specification

POWER INPUT

PoEx or separately powered

Input voltage

12V DC (10–15.4V)

Input current

160mA

Input protection

Fuse + supply reversal diode

ETHERNET

Intrinsically Safe 10/100 base T

Connector

RJ45

PoEx

Powered Device

FIBRE PORT

10/100 base FX

Connector

SC or ST (multi-mode), SC (single-mode)

OPTICAL FIBRE

Multi mode distance

2Km@100Mbps/5Km@10Mbps typ. (62.5/125)

Single mode distance

T.B.A.

TX Output (1300nm)

Multi mode -19dBm (min), -14dBm (max) *note1

Single mode -15dBm (min), -8dBm (max) *note2

RX Sensitivity

Multi mode -33.9dBm (ave), -31dBm (min)

Single mode -25dBm (min)

*note1 – transmit power coupled into 62.5/125um fibre, NA=0.275

*note2 – transmit power coupled into single-mode fibre

SAFETY

Eye Safety

Class1 Laser/LED product

Location of module

Zone 1, IIC T4 hazardous area

or Class 1, Div 1*, Groups A, B, C, D T4 hazardous location

Location of field wiring

Zone 0, IIC T4 hazardous area

or Class 1, Div 1*, Groups A, B, C, D T4 hazardous location

* Certification pending

Ethernet protection

intrinsically safe

Certification Code

See approvals

Safety description

See certificate

MECHANICAL

Mounting

DIN rail

Dimensions (mm)

Length 75

Width 55

Height (off rail) 116

Weight

700 g

LED INDICATORS

	OFF	FLASH	ON
PWR (green)	Power fail	N/A	Power OK
ACT (red)	Idle	Ethernet link activity	Ethernet link activity
10 (yellow)	No Ethernet link at 10Mbps	Poor link	Ethernet connected at 10Mbps
100 (green)	No Ethernet link at 100Mbps	Poor link	Ethernet connected at 100Mbps

ENVIRONMENTAL

Ambient temp

Operating -20°C to +70°C

Storage -20°C to +70°C

Relative Humidity

5 to 95% RH (non-condensing)

Ingress Protection

IP20 to BS EN 60529

(Additional protection by means of enclosure)

DATA & POWER TERMINALS

LAN (RJ45)

10/100 BASE-T Ethernet
(TX/RX crossed MDI-X)

Pin	Function
1	Rx +
2	Rx -
3	Tx +
4	Supply 12V - PoEx †
5	Supply 12V - PoEx †
6	Tx -
7	Supply 0V - PoEx †
8	Supply 0V - PoEx †

10/100 BASE-FL Ethernet

ST(or SC) - Fibre Optic

Top Port TX

Bottom Port RX

Screw Terminals †

PWR	Function
1	+12V DC in
2	+12V DC in
3	0V
4	0V
5-8	No connections

Terminals 1+2 and 3+4 are linked internally.

† When using PoEx, no supply is required on screw terminals 1 to 4



EUROPE (EMEA)
AMERICAS
ASIA PACIFIC
E-mail: enquiry@mtl-inst.com

Tel: +44 (0)1582 723633
Tel: +1 603 926 0090
Tel: +65 6 487 7887

Fax: +44 (0)1582 422283
Fax: +1 603 926 1899
Fax: +65 6 487 7997
Web site: www.mtl-inst.com



9466-ET



- ◆ **Zone 1 mountable in IP6x enclosure**
- ◆ **5-port 10/100Mbps links**
- ◆ **Broadcast "storm" protection**
- ◆ **Intelligent Routing**
- ◆ **Programmable Management**
- ◆ **ATEX / IECEx certified**
- ◆ **FM / CSA approvals (pending)**
- ◆ **Wide temp. range -20°C to +70°C**
- ◆ **Half/Full Duplex**
- ◆ **Power source for PoEx™ Power over IS Ethernet**
- ◆ **Status LEDs to show activity**

The 9466-ET 10/100Mbps, Layer 2, Ethernet switch allows the interconnection of MTL 9400-ET series networking modules via its 5 ports. It also enables an Ethernet network to cover a greater distance using either Cat5e cable or fibre-optic for longer spans. This capability is due to the low latency 'store and forward' mechanism integral to the switch, which ensures that the stringent timing associated with Ethernet is maintained.

With the 9466-ET switch each connection is effectively a 'point-to-point' network segment unlike the older generation hubs that were simple 'dumb' repeaters. The old hubs needed to impose a limit on overall network length to ensure proper collision detection; this limit is overcome by the 9466-ET. Broadcast "storm" protection is also provided to eliminate network overload due to excessive 'broadcast' & 'multicast' packets.

The 9466-ET switch can also distribute power to compatible devices connected to each of its five ports via the RJ45 Cat5e cables (PoEx). This method eliminates the separate power supply cable to the device simplifying installation and maintenance.

The 9466-ET is designed for Zone 1 hazardous-area mounting inside a suitable IP6x enclosure and has intrinsically safe ATEX and IECEx approvals with FM

and CSA approvals pending. The approvals cover both surface industry and mining applications.

The default mode of operation is a 5-port, unmanaged switch with auto negotiation. However the onboard EEPROM memory can be configured via the serial RS232/TTL port either in the safe area, using a PC, or in the hazardous area using the 9461-ET Ethernet Gateway as its host processor.

Programmable features such as Rate Limiting, VLAN support and Forced Speed and Duplex settings may be configured in this way, along with access to MIB counters etc. The 9466-ET also has Intelligent Routing with automatic address learning, aging and migration.

It supports IEEE 802.3: 10Base-T, 100Base-TX and also MDI / MDI-X auto crossover, for easy cascading of switches with standard cables.

The module is supplied as a DIN-rail mounting device.

PoEx is a trademark of Controlled Systems Limited



SPECIFICATION

See also System Specification

POWER INPUT

Separately powered

Input voltage

12V DC (10–15.4V)

Input current

200mA

Input protection

Fuse + supply reversal diode

ETHERNET

Intrinsically Safe 10/100 base T, auto negotiation speed and X-over

Ports

5

Connector

RJ45

PoEx

Power Source Equipment, each port selectable by connection of IS power supply such as 9491-IS

TECHNOLOGY

Standards

IEEE802.3, 802.3u, 802.3x, 802.1d, 802.1p, 802.1q

Protocols

IGMP V1/V2 device,

MIB Counters

(via RS232 port)

Flow Control

IEEE802.3x flow control, back pressure flow control

IS RS232 MANAGED SWITCH CONNECTION

Number of channels

1

Connector Type

8-pin mini-DIN

Baudrate

115K2baud

Parity

None

Data Bits

8

Stop Bits

1

Flow Control

None

SAFETY

Location of module

Zone 1, IIC T4 hazardous area
or Class 1, Div 1*, Groups A, B, C, D T4 hazardous location

Location of field wiring

Zone 0, IIC T4 hazardous area
or Class 1, Div 1*, Groups A, B, C, D T4 hazardous location

* Certification pending

Ethernet protection

intrinsically safe

Certification Code

See approvals

Safety description

See certificate

MECHANICAL

Mounting

DIN rail

Dimensions (mm)

Length 75

Width 100

Height (off rail) 116

Weight

1200 g

LED INDICATORS

	OFF	FLASH	ON
PWR (green)	Power fail	N/A	Power OK
WDG (red)	Watchdog Fault	Healthy (10Hz)	Watchdog Fault
FDX (red)	Half Duplex	N/A	Full Duplex
10 ACT (yellow)	No Ethernet link at 10Mbps	Ethernet connected and activity at 10Mbps	Ethernet connected at 10Mbps
100 ACT (green)	No Ethernet link at 100Mbps	Ethernet connected and activity at 100Mbps	Ethernet connected at 100Mbps

ENVIRONMENTAL

Ambient temp

Operating –20°C to +70°C

Storage –20°C to +70°C

Relative Humidity

5 to 95% RH (non-condensing)

Ingress Protection

IP20 to BS EN 60529

(Additional protection by means of enclosure)

DATA & POWER TERMINALS

LAN PORTS (RJ45) 10/100 BASE-T Ethernet

Pin	Function
1	Tx +
2	Tx –
3	Rx +
4	Supply 12V - PoEx †
5	Supply 12V - PoEx †
6	Rx –
7	Supply 0V - PoEx †
8	Supply 0V - PoEx †

All five RJ45 ports are identical.

Screw Terminals

Terminal	Function	
1	+12V DC in	9466 module supply input
2	+12V DC in	
3	0V	
4	0V	
5	No Connection	
6	+12V DC in	(PoEx – Port1)
7	0V	
8	+12V DC in	(PoEx – Port2)
9	0V	
10	+12V DC in	(PoEx – Port3)
11	0V	
12	+12V DC in	(PoEx – Port4)
13	0V	
14	+12V DC in	(PoEx – Port5)
15	0V	

Notes:

1. Terminals 1+2 and 3+4 are linked internally

2. When using PoEx – ‘inject’ device power into terminals 6 to 15 as required



EUROPE (EMEA)
AMERICAS
ASIA PACIFIC
E-mail: enquiry@mtl-inst.com

Tel: +44 (0)1582 723633
Tel: +1 603 926 0090
Tel: +65 6 487 7887

Fax: +44 (0)1582 422283
Fax: +1 603 926 1899
Fax: +65 6 487 7997

Web site: www.mtl-inst.com



9468-ET



- ◆ **Zone 2 mountable for connections to Zone 0 and 1**
- ◆ **Galvanically isolated RJ45 ports**
- ◆ **Transparent operation**
- ◆ **Compact alternative solution to fibre optics and media converters**
- ◆ **ATEX / IECEx certified**
- ◆ **FM / CSA approvals (pending)**
- ◆ **Wide temp. range -20°C to +70°C**
- ◆ **Single 20-30V DC power supply**
- ◆ **Status LEDs to show activity**

The 9468-ET 10/100Mbps, Isolating Ethernet Barrier allows the interconnection of a Zone 2 or un-certified safe area device to the intrinsically safe 9400-ET series of Ethernet networking products, operating in the hazardous area.

The isolating barrier provides a compact alternative solution to fibre optic cable and media converters and for when it is desirable to use Cat5e cables in preference to fibre.

The 9468-ET is designed for Zone 2 hazardous-area mounting inside a suitable IP6x enclosure and has intrinsically safe ATEX and IECEx approvals, with FM and CSA approvals pending. The approvals cover both surface industry and mining applications.

10/100Mb Ethernet twisted pair (Cat5e) RJ45 connections (100metres length max). These RJ45 ports provide total galvanic isolation ($U_m=253V_{ac}$) from safe to hazardous areas.

Status LEDs are provided on the front panel to indicate:

- 'Power On'
- Safe Area UTP 'Link 10/100Mb' established
- Safe Area UTP 'Tx/Rx Activity'
- Haz. Area UTP 'Link 10/100Mb' established
- Haz. Area UTP 'Tx/Rx Activity'

The module operates from a single supply in the Safe Area of 20...30Vdc at approx 220mA.

Transparent operation - 10/100Mbps, Full/Half Duplex with Auto-Negotiation. Supports IEEE 802.3: 10Base-T and 100Base-TX.

The module is supplied as a DIN-rail mounting device.



SPECIFICATION

See also System Specification

POWER INPUT

Separately powered Input voltage

24V DC (20–30V)

Input current

220mA

Input protection

Fuse + supply reversal diode

GENERAL PURPOSE ETHERNET

10/100 base T

Connector

RJ45

IS ETHERNET

Intrinsically Safe 10/100 base T

Connector

RJ45

PoEx

Power Source Equipment, on hazardous area LAN by connection of IS power supply such as 9491-IS

SAFETY

Location of module

Safe Area, Zone 2, Division 2*

Location of field wiring

Zone 0, IIC T4 hazardous area*
or Class 1, Div 1*, Groups A, B, C, D T4 hazardous location
*Certification pending

Ethernet protection

Intrinsically safe

Certification Code

See approvals

Safety description

See certificate

MECHANICAL

Mounting

DIN rail

Dimensions (mm)

Length 75

Width 100

Height (off rail) 116

Weight

380 g

LED INDICATORS

	OFF	FLASH	ON
PWR (green)	24V Power fail	N/A	24V Power OK
ACT (red)	Idle	Ethernet link activity	Ethernet link activity
10 (yellow)	No Ethernet link at 10Mbps	Poor link	Ethernet connected at 10Mbps
100 (green)	No Ethernet link at 100Mbps	Poor link	Ethernet connected at 100Mbps

ENVIRONMENTAL

Ambient temp

Operating –20°C to +70°C

Storage –20°C to +70°C

Relative Humidity

5 to 95% RH (non-condensing)

Ingress Protection

IP20 to BS EN 60529

(Additional protection by means of enclosure)

DATA & POWER TERMINALS

LAN Terminals (RJ45)

10/100 BASE-T Ethernet

Safe Area and Hazardous Area (marked blue)

Pin	Function
1	Rx +
2	Rx –
3	Tx +
4	Supply 12V - PoEx †
5	Supply 12V - PoEx †
6	Tx –
7	Supply 0V - PoEx †
8	Supply 0V - PoEx †

Tx/Rx crossed
MDI-X

Screw Terminals

PWR	Function
1	+20 – 30V DC in
2	+20 – 30V DC in
3	0V
4	0V
5-13	No connections
14	Supply in 12V - PoEx †
15	Supply in 0V - PoEx †

Terminals 1+2 and 3+4
are linked internally.

† When using PoEx, inject
device power into terminals
14 & 15 (marked blue).



EUROPE (EMEA)
AMERICAS
ASIA PACIFIC
E-mail: enquiry@mtl-inst.com

Tel: +44 (0)1582 723633
Tel: +1 603 926 0090
Tel: +65 6 487 7887

Fax: +44 (0)1582 422283
Fax: +1 603 926 1899
Fax: +65 6 487 7997

Web site: www.mtl-inst.com



9469-ET

**Intrinsically Safe
Wireless
Access Point/Bridge**



- ◆ **Tri-Band operation**
- ◆ **Convert Ethernet device to wireless**
- ◆ **Zone 1 mountable in IP6x enclosure**
- ◆ **Multi-country roaming**
- ◆ **10/100Mbps Ethernet**
- ◆ **ATEX / IECEx certified**
- ◆ **FM / CSA approvals (pending)**
- ◆ **Wide temp. range -20°C to +60°C**
- ◆ **PoEx™ Power over IS Ethernet option**

The 9469-ET is a multi-functional module that can be used as an Access Point, Wireless Bridge (Client) or Wireless Repeater

When used in the Access Point (AP) mode, it allows wireless devices to connect through it and onto the wired Ethernet network, either in AD-HOC or Infrastructure modes.

When used as a Bridge, it makes it possible to turn any 10/100 Ethernet device into a wireless device, or to connect two network segments together to make a single network (without the interconnecting wire or fibre optic).

Additionally the module may also be used in its Wireless Repeater (WDS) mode to extend the range covered by a wireless network.

The 9469-ET is designed for Zone 1 hazardous-area mounting inside a suitable IP6x enclosure and has intrinsically safe ATEX and IECEx approvals with FM and CSA approvals pending. The approvals cover both surface industry and mining applications.

The unit may be powered by an intrinsically safe power supply or by Power over IS Ethernet (PoEx) providing intrinsically safe power and Ethernet communications over a single Cat5e cable.

The Tri-Band operation offers flexibility in situations where the 2.4GHz band may be overcrowded or where operation in the 5GHz and 5.4GHz bands is desired. Optional dual antennae also provide diversity improving wireless operation.

The intrinsically safe approval of the 9469-ET allows the use of a wider range of antennae that are classified as "simple apparatus". The ANT94 omnidirectional antenna (2.4GHz, 3dBi gain) is ideal for use where good general coverage is required.

Compliant with IEEE 802.11 a/b/g/h & Super AG standards, up to 108 Mbps data rate and provides security: WEP, WPA-PSK, WPA2-PSK and IEEE 802.1X (RADIUS).

Status LEDs are provided on the front panel for:

- 'Power On'
- WLAN 'Activity'
- Copper UTP 'Activity'
- Copper UTP '10/100Mb Link'

Configuration is straight forward with an easy to use web based application. The unit supports 802.11d (multi-country roaming) which allows the country to be selected during setup, ensuring the configuration complies with regulatory limits.

The module is supplied as a DIN-rail mounting device.

PoEx is a trademark of Controlled Systems Limited



EUROPE (EMEA)
AMERICAS
ASIA PACIFIC
E-mail: enquiry@mtl-inst.com Web site: www.mtl-inst.com

Tel: +44 (0)1582 723633
Tel: +1 603 926 0090
Tel: +65 487 7887

Fax: +44 (0)1582 422283
Fax: +1 603 926 1899
Fax: +65 487 7997

Oct 2008

SPECIFICATION

See also System Specification

POWER INPUT

PoEx or separately powered

Input voltage

12V DC (10–12.8V)

Input current

270mA

Input protection

Fuse + supply reversal diode

IS ETHERNET

Intrinsically Safe 10/100 base T

Connector

RJ45

PoEx

Powered Device

WLAN

Standards

IEEE 802.11a/b/g/h

Frequency range

2.4 / 5 / 5.4GHz

Data Rate

up to 108Mbps (Super AG mode)

Modulation

OFDM: BPSK, QPSK, 16QAM, 64QAM, DSSS: DBPSK, DQPSK, CCK

Operating channels (802.11bg)

USA / Canada 1-11

Europe / Australia 1-13

Japan 1-14 (channel 14 for 802.11b only)

Security

64/128 bits WEP, WPA-PSK, WPA2-PSK, IEEE 802.11x (RADIUS) authentication, MAC address filtering, SSID broadcast control

Transmit power

+20dBm with TPC (100mW max)

RX Sensitivity

-92dBm for IEEE 802.11a/g

-95dBm for IEEE 802.11b

SOFTWARE

Administration

Web based management using any standard web browser (Internet Explorer, Netscape, Mozilla...), SNMP agent

SAFETY

Location of module

Zone 1, IIC T4 hazardous area
or Class 1, Div 2, Groups A, B, C, D T4 hazardous location*

Location of field wiring

Zone 0, IIC T4 hazardous area
or Class 1, Div 1, Groups A, B, C, D T4 hazardous location*

Ethernet protection

intrinsically safe

Certification Code

See approvals

Safety description

See certificate

MECHANICAL

Mounting

DIN rail

Dimensions (mm)

Length 75

Width 100

Height (off rail) 116

Weight

1200 g

LED INDICATORS

	OFF	FLASH	ON
PWR (green)	Power fail	N/A	Power OK
WLAN (yellow)	Idle	Wireless LAN data activity	N/A
STAT (red)	AP mode = Normal status. Bridge mode = connection to AP is established	Bridge mode = attempting to connect to AP	Fault
ACT (yellow)	Ethernet link disconnected	Ethernet link activity	Ethernet link connected
100 (green)	Ethernet link set to 10Mbps	N/A	Ethernet link is 100Mbps

ENVIRONMENTAL

Ambient temp

Operating -20°C to +60°C

(except where stated in individual module specifications)

Storage -20°C to +60°C

Relative Humidity

5 to 95% RH (non-condensing)

Ingress Protection

IP20 to BS EN 60529

(Additional protection by means of enclosure)



EUROPE (EMEA)
AMERICAS
ASIA PACIFIC

Tel: +44 (0)1582 723633
Tel: +1 603 926 0090
Tel: +65 6 487 7887

Fax: +44 (0)1582 422283
Fax: +1 603 926 1899
Fax: +65 6 487 7997

E-mail: enquiry@mtl-inst.com Web site: www.mtl-inst.com

Oct 2008



9491-PS

**12V DC
Intrinsically Safe
Power Supply**



- ◆ **Isolated power supply**
- ◆ **Zone 2 mountable**
- ◆ **DIN-rail or backplane mounting**
- ◆ **ATEX / IECEx certified**
- ◆ **FM / CSA approvals (pending)**
- ◆ **200mA @10.9V DC - Ex ia IIB output**
- ◆ **400mA @11.8V DC - Ex ib IIB output**
- ◆ **Power over Ethernet option**
- ◆ **Multiple outputs achieved by ganging 9491-PS modules using 24V DC power distribution backplane**

The 9491-PS Power Supply is the preferred method for supplying the 9460-ET series of intrinsically safe Ethernet modules and is based on an isolating power supply. It takes a 24V DC safe area / Zone 2 supply and produces an intrinsically safe, 12V DC nominal output capable of powering the Ethernet modules mounted in a Zone 1 hazardous area.

Each 9491-PS can power a single Ethernet module. In order to provide multiple outputs required for several Ethernet modules, the 9491-PS power supply module is ganged up to the required number of ways, either DIN-rail mounted or using the power distribution backplane to simplify the 24VDC input connection to the modules.

The 9491-PS module has LED power indication for both input and output along with internal current limiting and electronic auto-reset circuit breaker action to protect the module in the event of its output being short circuited or overloaded. This also minimises the power dissipation during the fault to a negligible level, thus improving reliability.

The output can be from either the Ex ia IIB or Ex ib IIB output connectors depending upon application. The 'ib' IIB output providing a higher useable output power where the Gas Group and Zone allows.



EUROPE (EMEA)
AMERICAS
ASIA PACIFIC
E-mail: enquiry@mtl-inst.com

Tel: +44 (0)1582 723633
Tel: +1 603 926 0090
Tel: +65 487 7887

Fax: +44 (0)1582 422283
Fax: +1 603 926 1899
Fax: +65 487 7997

Web site: www.mtl-inst.com

Oct 2008

SPECIFICATION

See also System Specification

POWER INPUT

Separately powered

Input voltage

24V DC (20–30V)

Input current

350mA

Input protection

Fuse + supply reversal diode

POWER OUTPUT

Ex ia IIB output

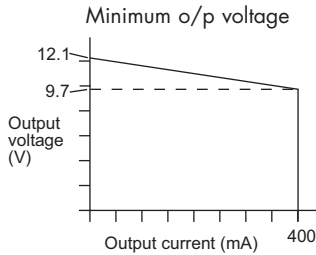

Equivalent circuit

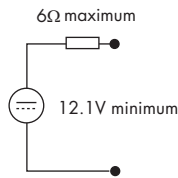

Ex ib IIB output

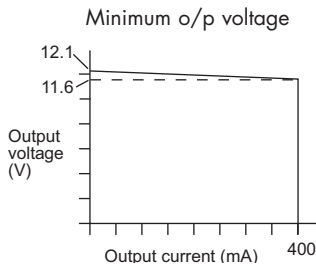

Equivalent circuit

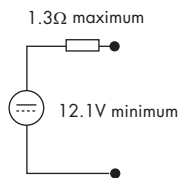

Connectors

9491-PS is supplied with two IS output connectors.
(When using crimp ferrules for the IS connectors the metal tube length should be 12mm and the wire trim length 14mm.)

ISOLATION

Isolation - input to output

$U_m = 253V$ rms

SAFETY

Location of module

Safe area, Zone 2*, Division 2*

Location of field wiring

Ex ia output

Zone 0, IIB hazardous area
or Class 1, Div 1, Groups C, D hazardous location*

Ex ib output

Zone 1, IIB hazardous area
or Class 1, Div 1, Groups C, D hazardous location*

Certification Code

See approvals

Safety description

See certificate

MECHANICAL

Mounting

DIN rail or power distribution backplane

Dimensions

See diagram

Weight

130 g

DIMENSIONS (mm)

Optional TH5000 tag holder for individual module identification.
Accepts tag label 25 x 12.5 ±0.5mm, 0.2mm thick

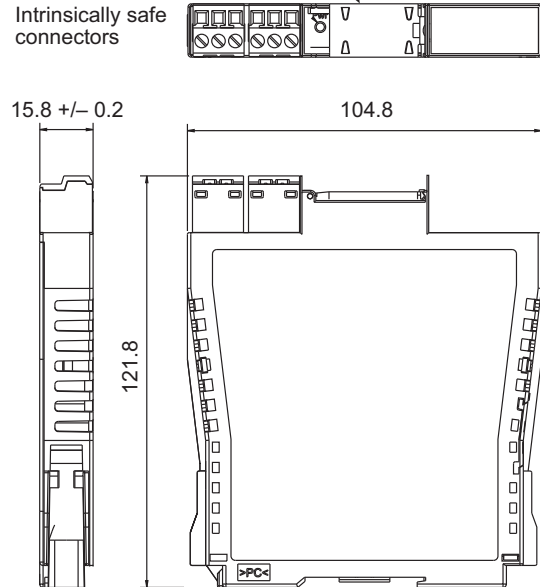

ENVIRONMENTAL

Ambient temp

Operating 0°C to +70°C

Storage -20°C to +70°C

Relative Humidity

5 to 95% RH (non-condensing)

Ingress Protection

IP20 to BS EN 60529

(Additional protection by means of enclosure)

LED INDICATORS

	OFF	Flash	ON
Pwr (green)	24V power fail	N/A	24V power OK
IS (green)	IS power fail	output overload or short circuit present	IS power OK

* certification pending



EUROPE (EMEA)
AMERICAS
ASIA PACIFIC
E-mail: enquiry@mtl-inst.com

Tel: +44 (0)1582 723633
Tel: +1 603 926 0090
Tel: +65 6 487 7887

Fax: +44 (0)1582 422283
Fax: +1 603 926 1899
Fax: +65 6 487 7997

Web site: www.mtl-inst.com

Oct 2008

9400 SERIES

SYSTEM SPECIFICATION

MECHANICAL

Mounting method

DIN-rail

DIN-rail types

'Top hat', 35 x 7.5 mm to EN 50022 or DIN 46277

ENVIRONMENTAL

Ambient temp

Operating -20°C to + 70°C
(except where stated in individual module specifications)
Storage -20°C to + 70°C

Relative Humidity

5 to 95% RH (non-condensing)

Ingress Protection

IP20 to BS EN 60529
(Additional protection by means of enclosure)

ELECTRICAL

EMC compliance

To EN61326:1998 Electrical equipment for measurement, control and laboratory use – EMC requirements

Electrical safety

EN 61010-1

APPLICABLE STANDARDS:

- Factory Mutual Research Co., Class No. 3610 for Class I, II, III, Divisions 1 and 2, Groups A - G hazardous locations (Intrinsically safe circuits).
- Factory Mutual Research Co., Class No. 3611 for Class I, Division 2, Groups A, B, C, D hazardous locations
- EN 60079-0:2006, IEC 60079-0:2004 Electrical apparatus for explosive gas atmospheres – General requirements
- EN 60079-11:2007, IEC 60079-11:2006 Explosive atmospheres -Equipment protection by intrinsic safety "i"
- EN/IEC 60079-15:2005 Electrical apparatus for explosive gas atmospheres - Construction, test and marking of type of protection "n" electrical apparatus
- EN 60079-25:2004, IEC 60079-25:2003 Electrical apparatus for explosive gas atmospheres - Intrinsically safe systems 'i'
- IEC 61241-0:2004 Electrical apparatus for use in the presence of combustible dust. General requirements
- IEC 61241-11:2005 Electrical apparatus for use in the presence of combustible dust. Protection by intrinsic safety "iD"
- EN 50303:2000 Group I, Category M1 equipment intended to remain functional in atmospheres endangered by firedamp and/or coal dust
- EC Directive 94/9/EC (ATEX 100A)

PHYSICAL NETWORK

Ethernet



APPROVALS

9461-ET, 9465-ET-x-xx, 9466-ET

Region	Europe (ATEX)	International IECEx	USA	Canada
Authority	SIRA	SIRA	FM	CSA
Standard	EN 60079-0:2006, EN 60079-11:2007, IEC 60079-26:2006†, EN 50303:2000, IEC 61241-0:2004, IEC 61241-11:2005	IEC 60079-0:2004, IEC 60079-11:2006, IEC 61241-0:2004, IEC 61241-1:2004		
Approved for	⊕ II 1GD Ga Ex ia IIC T4 Ex iaD 20 T135°C (Ta = -40°C to +70°C) ⊕ I M1 Ma Ex ia I (Ta = -40°C to +70°C)	Ga Ex ia IIC T4 Ex iaD 20 T135°C Ma Ex ia I (Ta = -40°C to +70°C)		
Cert. no.	Sira 07ATEX2064X	IECEX SIR 07.0042X	Pending	Pending

† (for guidance on Ma & Ga marking)

9469-ET

Region	Europe (ATEX)	International IECEx	USA	Canada
Authority	SIRA	SIRA	FM	CSA
Standard	EN 60079-0:2006, EN 60079-11:2007, IEC 60079-26:2006, EN 50303:2000, IEC 61241-0:2004, IEC 61241-11:2005	IEC 60079-0:2004, IEC 60079-11:2006, IEC 61241-0:2004, IEC 61241-1:2004		
Approved for	⊕ II 1GD Ga Ex ia IIC T4 Ex iaD 20 T135°C (Ta = -40°C to +60°C) ⊕ I M1 Ma Ex ia I (Ta = -40°C to +60°C)	Ga Ex ia IIC T4 Ex iaD 20 T135°C Ma Ex ia I (Ta = -40°C to +60°C)		
Cert. no.	Sira 07ATEX2064X	IECEX SIR 07.0042X	Pending	Pending

9468-ET

Region	Europe (ATEX)	International IECEx	USA	Canada
Authority	SIRA	SIRA	FM	CSA
Standard	EN 60079-0:2006, EN 60079-11:2007, IEC 60079-26:2006, IEC 61241-0:2004, IEC 61241-11:2005	IEC 60079-0:2004, IEC 60079-11:2006, IEC 60079-26:2006, IEC 61241-0:2004, IEC 61241-11:2005		
Approved for	⊕ II (1) GD ⊕ I (M1) (Ga) [Ex ia] IIC [Ex iaD] (Ma) [Ex ia] I (Ta = -40°C to +70°C)	(Ga) [Ex ia] IIC [Ex ia D] (Ma) [Ex ia] I (Ta = -40°C to +70°C)		
Cert. no.	Sira 07ATEX2065	IECEX SIR 07.0 043	Pending	Pending
Standard	EN 60079-0:2006, IEC 60079-0:2007*, EN 60079-11:2007, EN 60079-15:2005, IEC 60079-26:2006	IEC 60079-0:2004, IEC 60079-11:2006, IEC 60079-15:2005-03		
Approved for	⊕ II 3 G Ex ic (ia) IIC T4 Gc (Ta = -40°C to +70°C) Ex nLc nAc (ia) IIC T4 (Ta = -40°C to +70°C)	Ex ic [ia] IIC T4 Gc (Ta = -40°C to +70°C) Ex nLc nAc [ia] IIC (Ta = -40°C to +70°C)		
Cert. no.	Sira 08ATEX4130X	IECEX SIR 08.0032X		

* (for guidance on the Gc, nLc & nAc marking)

(continued on next page)



EUROPE (EMEA)
AMERICAS
ASIA PACIFIC
E-mail: enquiry@mtl-inst.com

Tel: +44 (0)1582 723633
Tel: +1 603 926 0090
Tel: +65 6 487 7887

Fax: +44 (0)1582 422283
Fax: +1 603 926 1899
Fax: +65 6 487 7997

Web site: www.mtl-inst.com

Oct 2008

9491-PS

Region	Europe (ATEX)	International IECEx	USA	Canada
Authority	SIRA	SIRA	FM	CSA
Standard	EN 60079-0:2006, EN 60079-11:2007, IEC 60079-26:2006, IEC 61241-0:2004, IEC 61241-11:2005	IEC 60079-0:2004, IEC 60079-11:2006, IEC 61241-0:2004, IEC 61241-11:2005		
Approved for	⊕ II (1/2) GD (Ga) [Ex ia] IIB (Gb) [Ex ib] IIB [Ex iaD] [Ex ibD] ⊕ I (M1/M2) (Ma) [Ex ia] I (Mb) [Ex ib] I Ta = 0°C to +70°C	(Ga) [Ex ia] IIB (Gb) [Ex ib] IIB [Ex iaD] [Ex ibD] (Ma) [Ex ia] I (Mb) [Ex ib] I Ta = 0°C to +70°C		
Cert. no.	Sira 08ATEX2188	IECEx SIR 08.0072	Pending	Pending

ORDERING INFORMATION

Part No.	Description
9461-ET	IS serial to Ethernet gateway
9465-ET-M-ST	IS media converter
9465-ET-M-SC	IS media converter
9465-ET-S-SC	IS media converter
9466-ET	IS managed Ethernet switch
9468-ET	IS Ethernet isolator
9469-ET	IS wireless AP/bridge
ANT94	Omni-directional antenna - 2.4GHz, 3dBi gain
9491-PS	IS power supply
CSL9405-xxx	Copper twisted pair FTP Patch Cable (pre-terminated with RJ45 - RJ45 connectors) -xxx suffix denotes the cable length. Lengths available from 0.5m – 100m



Zentrale und Vertrieb:

MTL Instruments GmbH
An der Gumpgesbrücke 17
41564 Kaarst
Tel: 02131 / 71893-0
Fax: 02131 / 71893-33
info@MTL.de
www.MTL.de

Unsere Vertriebsniederlassungen:

Gebietsvertrieb Nord
HWFB Systemtechnik GmbH
Sven Möller
Im Hegen 11
22113 Oststeinbek
Tel: 040 / 7121052
Fax: 040 / 7122072
Sven.Moeller@MTL.de

Gebietsvertrieb Rhein/Ruhr
AS-Handelsvertretung & Vertrieb
Hartmut Aschenbruck
Eichendorffstrasse 26
41541 Dormagen
Tel: 02133 / 477630
Fax: 02133 / 244046
handelsvertretung.aschenbruck@t-online.de

Gebietsvertrieb Ost
Boewer Meßtechnik GmbH
Joachim Rickauer
Karl-Marx-Strasse 5
08451 Crimmitschau
Tel: 03762 / 9598-0
Fax: 03762 / 9598-20
Boewer-Messtechnik@MTL.de

**Key Account Süd und
Gebietsvertrieb Rhein / Main**
MTL Instruments GmbH
Dipl.-Ing. André Ammann
An der Gumpgesbrücke 17
41564 Kaarst
Tel: 02131 / 71893-18
Fax: 02131 / 71893-33
Andre.Ammann@MTL.de

Gebietsvertrieb Süd-West
MTL Instruments GmbH
Bernd Aufleger
An der Gumpgesbrücke 17
41564 Kaarst
Tel: 02131 / 71893-22
Fax: 02131 / 71893-33
Bernd.Aufleger@MTL.de

Gebietsvertrieb Süd
MTL Instruments GmbH
Johannes B. Bachmaier
An der Gumpgesbrücke 17
41564 Kaarst
Tel: 02131 / 71893-12
Fax: 02131 / 71893-33
Johannes.Bachmaier@MTL.de