

Redundant power system for fieldbus network segments

FPS-I SERIES

Redundant fieldbus power system

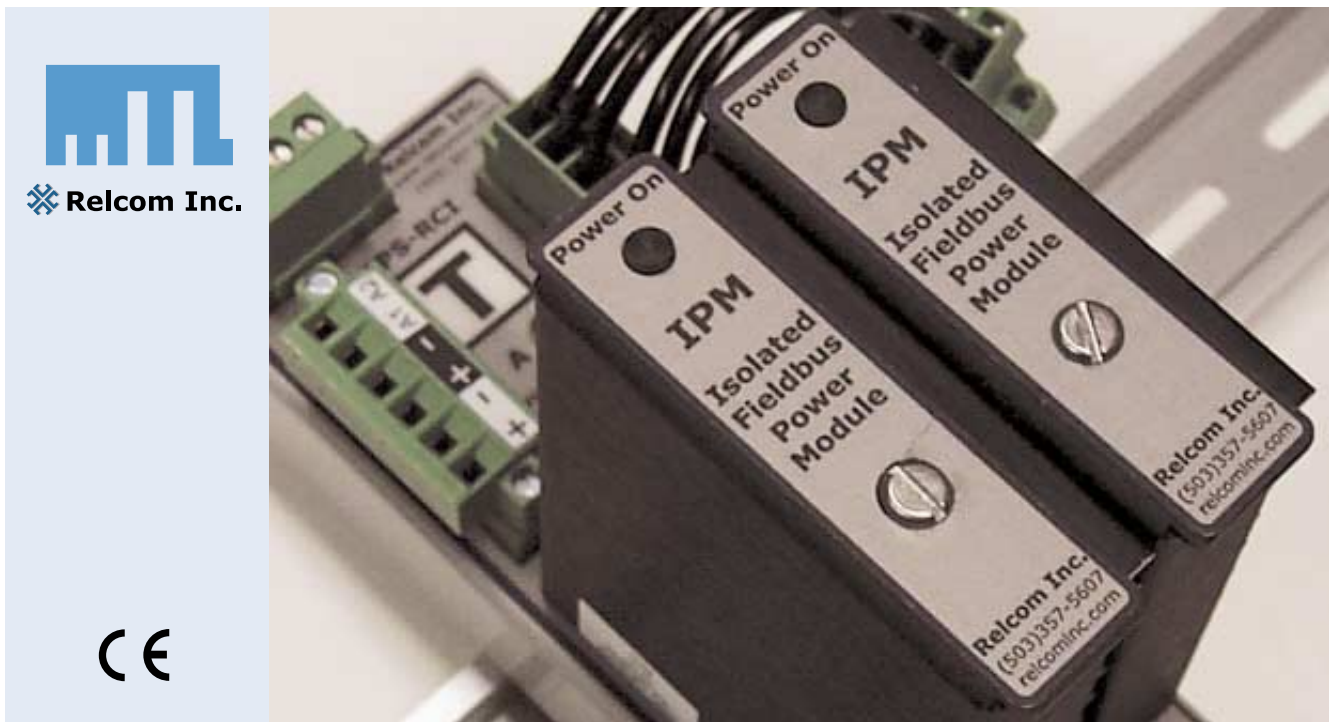

- ◆ **Redundant power conditioner for high availability applications**
- ◆ **Replace power modules without resetting the fieldbus**
- ◆ **High power output**
- ◆ **Two levels of power redundancy**
- ◆ **Component failure alarm**
- ◆ **Integrated fieldbus terminator**
- ◆ **Simplified power wiring**

The **MTL-Relcom redundant fieldbus power system (FPS-I Series)** provides redundant power conditioning for fieldbus network segments and facilitates the connection of redundant input power supplies. The system is fully 'hot-swappable' meaning that individual power conditioning modules and input power supplies can be replaced without interrupting power or communication on the fieldbus segment. An alarm circuit provides warning in case of a power conditioning module or input power supply failure. The system is designed so that power for several fieldbus segments can be provided from a single cabinet with minimal wiring.

One fieldbus segment terminator is built into each power system. Each FPS includes two plug-in power modules. These modules function as power conditioners, providing impedance between the input DC power supply and the fieldbus. This impedance is necessary to prevent the input DC power supply from degrading the digital fieldbus signal.

Each power module provides galvanic isolation of 250V ac between the fieldbus segment and the input power supplies. Each FPS-I supplies 350mA at 25V dc to the fieldbus segment. This output is maintained even if only one power module is installed. This level of output power allows for construction of very long fieldbus segments with a large number of bus-powered transmitters. Each FPS provides both power conditioning and input power supply redundancy to each fieldbus segment.

Green LED's on each power module and near each of the two input power supply connections give clear visual indication that components are functioning properly. To minimize system downtime, an alarm circuit provides notification if any of the power supply components fail. This allows failed components to be replaced so that power system integrity is maintained.

The alarm circuitry is galvanically isolated from the fieldbus segments and input power supplies. The two power modules plug into a DIN rail mounted backplane (Redundant Coupler or RCT) that contains one segment terminator and provides connections to the two input power supplies, H1 host system, fieldbus trunk cable, and alarm circuitry.

A bus configuration is used for the input power and alarm connections so that up to eight fieldbus power systems can be easily wired together to share input power supplies and provide a common alarm circuit. Pictured above is a Redundant Fieldbus Power Supply with connections to the Fieldbus H1 host shown at the top of the picture.

Segments that do not require the high availability provided by redundant power conditioning may be operated with only a single FPS-IPM. To prevent an unwanted alarm condition due to the second FPS-IPM not being fitted, a blanking module should be installed in the blank slot. These are supplied in a pack of 10 as part number FPS-BLK10.



FPS-I REDUNDANT FIELDBUS POWER SYSTEM

INSTALLATION

Mounting

MTL-Relcom Redundant Fieldbus Power Systems (FPS) are designed for mounting on 35mm DIN rail. For maximum cooling, the DIN rail should be mounted horizontally so that air can flow vertically between the power modules.

Input power supply connections

For redundant operation, two separate DC power supplies should be connected to each FPS. Four pairs of terminals are provided on each FPS for this purpose; two pairs for each input power supply. The extra pair of terminals for each input power supply are intended to be used for connection to another FPS installed immediately adjacent to the first. Prefabricated jumper assemblies are included with each FPS-I for this purpose. When multiple Fieldbus Power Systems are wired together using jumper assemblies, redundant connections should be made to the two input power supplies using the terminal pairs located at each end of the row of systems. Up to eight segments can be wired together using the supplied jumper assemblies. An example of three systems wired this way is shown below:

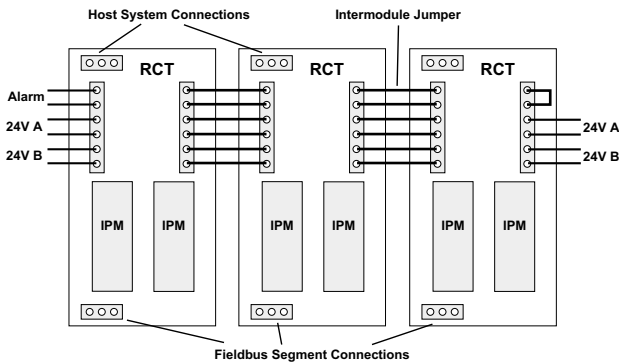

Alarm wiring connections

Next to the input power terminals, terminal pairs are provided for connection of the alarm circuit. Each prefabricated jumper assembly includes a pair of wires for the alarm circuit. To complete the alarm circuit, a jumper wire must be installed on the end module as shown below:

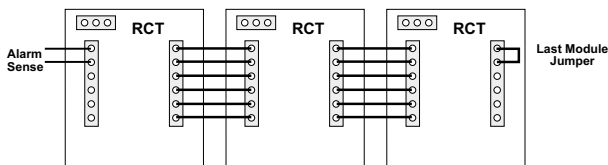

In normal operation, the alarm circuit is closed. It will open if:

- either input power supply < 18V dc
- output of either power module < 22V dc
- the fieldbus is shorted (short circuit resistance < 14Ω)

H1 host and fieldbus trunk connections

Two 3-conductor (+, shield, and -) connectors are provided for connection to the H1 host and to the fieldbus trunk cable. A green LED next to the connector labeled 'Fieldbus' indicates that power is being supplied to the fieldbus segment.

Fieldbus segment terminators

Two terminators are required for each Fieldbus H1 network segment. One terminator is built into the RCT backplane of each FPS. The second Terminator should be positioned at the opposite end of the segment trunk cable.

A Redundant Coupler without a built-in terminator is also available (part number FPS-RC).

Wiring

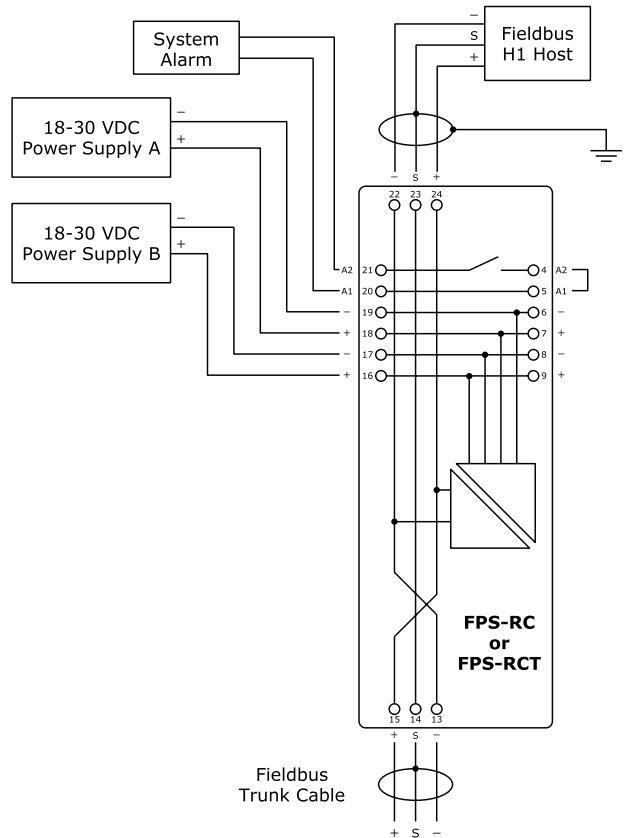

SPECIFICATION

MECHANICAL

Mounting method

DIN-rail

DIN-rail types

'Top hat', 35mm x 7.5mm or 35mm x 15mm to EN50022

Terminals

Rising cage clamp screw terminals

Physical Dimensions

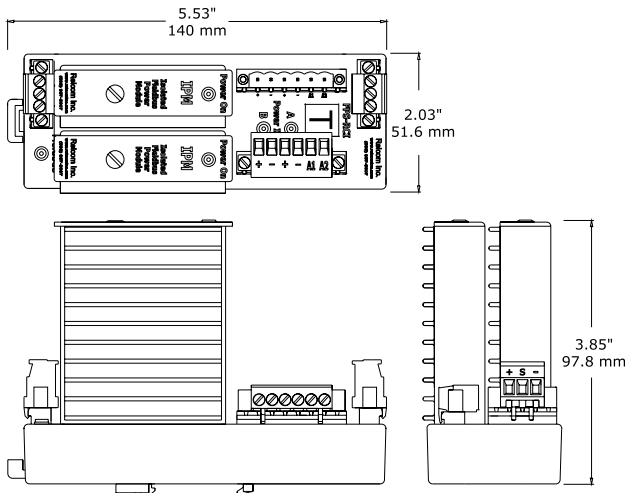

ENVIRONMENTAL

Ambient temp

Operating, optimum orientation *

-40°C to +65°C

Storage

-40°C to +85°C

*Optimum orientation is when the DIN rail is mounted horizontally on a vertical surface

Ingress Protection

IP20 to BS EN 60529 (Additional protection by means of enclosure)

Case Material

Redundant coupler

Lexan polycarbonate

ELECTRICAL

EMC compliance

To EN61326:1998 Electrical equipment for measurement, control and laboratory use - EMC requirements

Electrical safety

EN 61010-1

OUTPUT

Number of channels

One

Voltage

Minimum 25.0V dc

Current

0 to 350mA

Output ripple

Complies with clause 22.6.2 of the fieldbus standard

Minimum load

No load

Isolation

Fieldbus to power supply 250V ac rms withstand

INPUT

Input voltage

19.2 - 30V dc

Current consumption with 350mA output load

820mA (typical) 895mA (max.) at 18V

630mA (typical) 685mA (max.) at 24V

540mA (typical) 600mA (max.) at 28V

Power dissipation with 350mA output load

5.7W (typical)

Maximum number of cascaded FPS-I modules

8 units

Alarm

Alarm contact rating: 1.0A max @ 30Vdc max

Alarm contact status: Normally closed

Alarm threshold input: <18Vdc

output: <22Vdc

HAZARDOUS AREA APPROVALS

Location of module

Safe area, Zone 2, IIC T4 hazardous area or Class 1, Div 2,

Groups A, B, C, D T4 hazardous location

Location of field wiring

Zone 2, IIC hazardous area or Class 1, Div 2, Groups A, B,

C, D hazardous location

Field wiring protection

Normally non-arcing

CERTIFICATION

EUROPE (ATEX)

EN50021 II 3 G EEx nA IIC T4

500-463

USA (FM)

Class No.3611 Class1, Div 2 Grps A-D

Pending

CANADA (CSA)

C22.2 No.213 Class1, Div 2 Grps A-D; Ex nA IIC T4

1279454

PHYSICAL NETWORKS

IEC61158-2

Foundation Fieldbus H1

Profibus PA

ORDERING INFORMATION

Description	Part Number
Redundant Fieldbus Power System	FPS-I
Includes: 2 FPS-IPM	
1 FPS-RCT	
2 FPS-A01	
1 FPS-A03	
1 FPS-A04	
Redundant Fieldbus Power System (no terminator)	FPS-2
Includes: 2 FPS-IPM	
1 FPS-RC	
2 FPS-A01	
1 FPS-A03	
1 FPS-A04	
Components and Accessories	Part Number
Power Module	FPS-IPM
Redundant Coupler	FPS-RCT
Redundant Coupler (no Terminator)	FPS-RC
3-pin Fieldbus Connector	FPS-A01
Power and Alarm Connector	FPS-A03
Power and Alarm Jumper Assembly	FPS-A04
Blanking module (pack of 10)	FPS-BLK10
Heavy Duty DIN Rail End Stop	ETL 7000
35mm DIN Rail, 1 Meter Length	THR 7000



EUROPE (EMEA)
AMERICAS
ASIA PACIFIC
E-mail: enquiry@mti-inst.com

Tel: +44 (0)1582 723633
Tel: +1 603 926 0090
Tel: +65 487 7887

Fax: +44 (0)1582 422283
Fax: +1 603 926 1899
Fax: +65 487 7997

Web site: www.mti-inst.com, www.relcominc.com

November 2003